

**SAINT-GOBAIN SURFACE SOLUTIONS
ABRASIVES EMEA**

VENDOR MANUAL

VERSION 3 : September 2024



SAINT-GOBAIN SURFACE SOLUTIONS EMEA VENDOR MANUAL

WELCOME TO THE SAINT-GOBAIN SURFACE SOLUTIONS VENDOR MANUAL. WITH YOUR SUPPORT SAINT-GOBAIN SURFACE SOLUTIONS EUROPE AIMS AT DELIVERING A WORLD CLASS SERVICE.

This manual provides you with the information and the mandatory rules that apply to all strategic vendors. You will note our new expectations regarding sustainability for which Saint-Gobain has committed to reach the CO2 neutrality by 2050. Your pro-active engagement in that journey will be paramount to the success of our partnership.

Please take the time to read through the manual and understand your supply commitment from 2024.

Thank you for your continued support.

Arnaud Saint-Ourens

Vice-President Saint-Gobain Surface Solutions
EMEA



CONTENTS

4-7

Introduction

- 1 About Saint-Gobain Group..... 04
- 1.1 Introduction07
- 1.2 Purpose of this Specification07
- 1.3 Responsibilities07

8-11

Environment, Health & Safety

- 2.1 Overview 08
- 2.2 EHS Charter 09
- 2.3 Carbon Neutrality 09
- 2.4 Mobilization of suppliers and new initiatives in transport 09
- 2.5 Timber 09
- 2.6 Hazardous & Dangerous Products ... 10
- 2.7 Product Recyclability 10
- 2.8 Packaging 10
- 2.9 Product Safety 10
- 2.10 Site Safety Rules11

12-17

Quality

- 3.1 Declaration12
- 3.2 New Products/ Modifications.....13
- 3.3 Traceability Requirements.....14
- 3.4 Stability and Expiry Dates.....14
- 3.5 Product Recalls.....14
- 3.6 Guarantee15
- 3.7 Outer Package-Finished Goods15
- 3.8 Appendices16

18-35

Logistics

- 4.1 Purchase Order.....18
- 4.2 Delivery Note.....19
- 4.3 Palletised Deliveries DC/Warehouse.19
- 4.4 Spare Parts23
- 4.5 Parcel Deliveries24
- 4.6 Delivery Receipt Problems.....25
- 4.7 Vendor Returns.....26
- 4.8 Reimbursement of costs for Re-work/ Re-pack26
- 4.9 Scrap.....26
- 4.10 Appendices..... 27

36-39

Finance

- 5.1 Pricing36
- 5.2 Invoicing37
- 5.3 Invoice Discrepancies.....38
- 5.4 Payment.....38
- 5.5 Appendix.....39

40-49

Vendor Performance

- 6.1 Vendor Declaration 40
- 6.2 Purchase Order Acknowledgment ... 40
- 6.3 Vendor On Time Delivery Performance ..40
- 6.4 Vendor Pro-Active Communication ...41
- 6.5 Logistic Non-Conformance 42
- 6.6 Quality & Technical Non-Conformance..42
- 6.7 SGSS Customer Complaints 44
- 6.8 Supplier Performance Management44
- 6.9 Vendor Penalties45
- 6.10 Appendices 46

50-51

Specifics

- 7.1 Tools..... 50
- 7.2 Specifications, Drawings & Copyright .. 51

52-55

Annexe

- 1 Saint-Gobain EHS Charter.....52
- 2 Saint-Gobain Timber Policy54

INTRODUCTION

ABOUT SAINT-GOBAIN GROUP & SAINT-GOBAIN SURFACE SOLUTIONS

FOUNDED OVER

350

YEARS AGO

LOCATIONS IN

68

COUNTRIES

SAINT-GOBAIN RESEARCH

68

CROSS-BUSINESS R&D
CENTERS



AROUND

168,000

employees

AROUND

900

manufacturing facilities
around the world

AROUND

2,700

sales outlets

Our Vision

Creating surface solutions
for a better world



Our Mission

Together, committed to sustainability, we shape, protect and bond surfaces providing performance solutions for our customers.

Saint-Gobain Surface Solutions

A global business powered by solid brands that provide surface solutions for a better world. Our product offer includes abrasives, adhesives, sealants, tapes, and films. Together, committed to sustainability, we shape, protect and bond surfaces providing performance solutions for our customers.

visit: www.saint-gobain-surfacesolutions.com



Our key brands Norton, Flexovit, Clipper, Atlas, One Bond, Farecla and Winter are offered across a range of 40 000 products.

30

PLANTS &
LOGISTICS
SITES

25

OPERATIONS
IN COUNTRIES

9K

EUROPEAN
VENDORS

Every working hour, we place
more than 100 purchase orders...

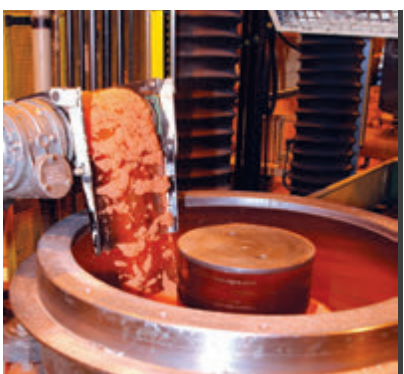
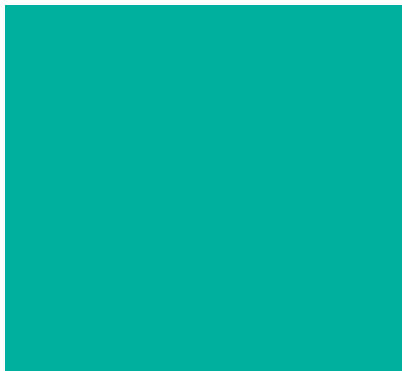

1.1 Introduction

This document sets out the EHS, Purchasing and Logistics requirements of Saint-Gobain Surface Solutions Europe. Please be aware that vendors must adhere to ALL of these requirements to ensure a successful operational relationship. If these requirements are not met, the vendor will be considered liable for any consequences, unless written specific agreement has been made with your Saint-Gobain Surface Solutions contact.

It is mandatory for the vendor to ensure their own vendors and sub-contractors follow the same rules outlined in this document.

Saint-Gobain Surface Solutions will be abbreviated as SGSS throughout this document.

1.2 Purpose of this Specification

The Vendor Manual details the requirements for vendors delivering product into SGSS's sites across Europe. SGSS endeavours to offer a world class service to our customers. Your role as a vendor is crucial to us in achieving this objective, therefore we need to ensure that all vendors are made aware and comply with the standards required by SGSS for the delivery of goods into our sites, whether deliveries are made using own transport or third party logistics providers. It is SGSS's policy to continually measure the performance of its vendors in relation to the specifications set out within this manual. We also carry out review meetings with each vendor to identify any areas of concern or non-conformance and to take the appropriate corrective action. All vendor non-conformances will therefore be recorded and managed by the SGSS Supply Chain/ Purchasing team. Please ensure that all relevant personnel in your organisation are aware of these requirements. By acknowledging our Purchase Order you will also be accepting the rules defined within this Vendor Manual. If you have any questions or concerns with your ability to adhere to the requirements in this document please contact your local SGSS Supply Chain and Purchasing Team.

1.3 Responsibilities

By supplying SGSS with strategic products, the vendor accepts the responsibility of the total supply chain in case of technical, quality, logistic and commercial deviation generated by him that could affect SGSS, any of its subsidiaries, subcontractors or customers.

If necessary, this risk shall be covered by an insurance contract undertaken by the vendor.

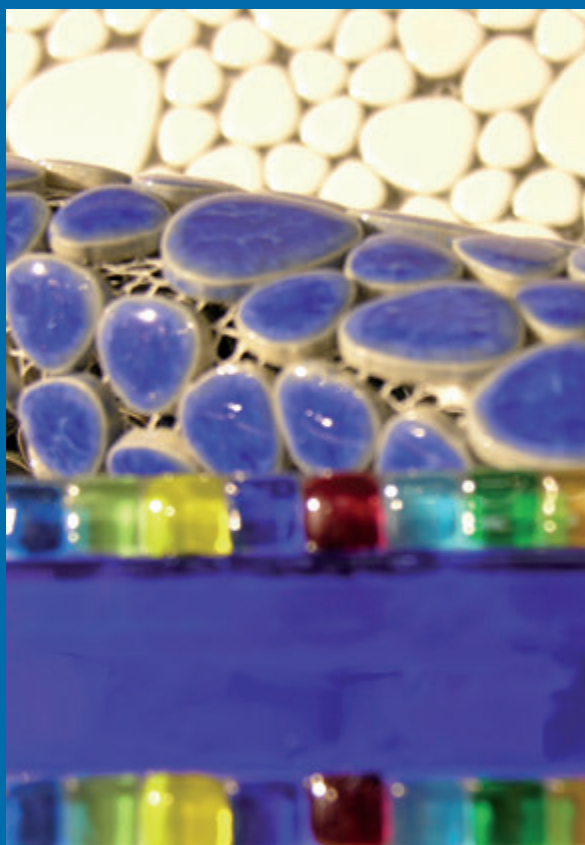

ENVIRONMENT, HEALTH & SAFETY



2.1 Overview

The vendor should be aware that the Saint-Gobain Group supports the UN Global Compact <http://www.unglobalcompact.org/> and has adopted General Principles of Conduct and Action, the values of which are shared with our vendors via the Supplier Charter.

The key principles are listed below:

- Respect the right to development
- Occupational Health and Safety
- Legal Compliance Commitment
- Employee Rights
- Environmental Commitment

The Supplier Charter can be provided by your Purchasing contact upon request or is available on the Internet site: <http://www.saint-gobain.com>

Vendors will receive a separate electronic request to sign up to the Supplier Charter periodically.

Saint-Gobain has started a process of evaluation of the CSR (Corporate Social Responsibility) of its vendors who may be requested to complete a questionnaire which could result in an audit. The vendor agrees to participate in this approach.

Saint-Gobain recommends that its vendors are accredited with an Environmental management system e.g ISO 14001.

All Saint-Gobain Responsible Purchasing Policies are available in Saint-Gobain supplier's portal

2.2 EHS Charter

The Saint-Gobain EHS Charter is available in Annex 1 (key principles below):

- **ZERO** work related accidents
- **ZERO** occupational illnesses
- **ZERO** environmental accidents and minimum impact of our activities

Saint-Gobain Surface Solutions is committed to actively pursuing its EHS policy through ambitious objectives which not only include its own workers but also those of onsite contractors and 3rd party vendors.

2.3 Carbon Neutrality

Saint-Gobain today sets out its CO2 roadmap for achieving carbon neutrality. The roadmap incorporates the Group's new commitments through to 2030 in terms of reducing not only its direct and indirect carbon dioxide emissions, but also the emissions along its value chain. These new targets for 2030 have been validated by the Science-Based Targets (SBT) initiative¹ which considers them aligned with the Group's 2050 net-zero commitment. To meet its targets, Saint-Gobain will dedicate a targeted capital expenditure and R&D budget of around €100 million per year until 2030. This approach will be the basis for the decisions that the Group will take to achieve carbon neutrality by 2050.

2.4 Mobilization of suppliers and new initiatives in transport:

For suppliers: comparison of their performance on the basis of CO2 emissions criteria both in terms of their operations and for the products concerned, signature of our Responsible Purchasing Charter, collection of detailed information on their commitments in terms of sustainable development, encouraging large emitters to adopt an SBT approach;

For transport: optimized logistics, fuel efficiency improvements, use of decarbonized fuels, replacement of road transport by rail & water, working alongside logistics suppliers.

2.5 Timber

SGSS has issued a timber policy available in Annex 2, outlining specific requirements of responsible conduct for sourcing or selling timber based products. FSC/PEFC principles currently represent the best method of achieving sustainable timber sourcing, albeit recognising that others may evolve in the near future. Pay particular attention to the EUTR policy; SGSS will ask for traceability.

Saint-Gobain gives priority to recycled products first in our purchasing and sales policies, then either PEFC/FSC certified products or timber from responsibly managed forests.



2.6 Hazardous & Dangerous Products

2.6i European regulation reach (registration, evaluation and autorisation of chemicals)

The vendor accepts to respect applicable laws & regulations related to chemicals, regardless of whether these substances are supplied to be used on their own, in mixtures, in articles or in their packaging.

The vendor especially commits to comply with the European REACH Regulation n° 1907/2006 concerning the registration, evaluation, authorisation and restriction of chemical substances and the CLP European Regulation (CE) n° 1272/2008 on the classification, labelling and packaging of substances and mixtures.

Therefore:

- If the product or its packaging contain substance(s) that must be registered with the European Chemicals Agency, the vendor guarantees that the substance(s) have been pre-registered and/or have been or will be registered for our uses, within the deadlines set by REACH;
- If the product or its packaging contain substance(s) of very high concern included in the Candidate List above 0.1%, the vendor undertakes to inform us, seek possible substitute and give at least six (6) months' notice if he intends either to stop selling the product and/or modify the ingredients; in this case, an initial sample shall be presented.
- If the product or it's packaging contain substance(s) subject to authorisation or restriction, the vendor undertakes to supply only those substances duly authorised for our uses and to comply with the restriction measures imposed by REACH.

2.6ii Hazardous products

For hazardous chemical products, a Safety Data Sheet (SDS) must be provided and sent to the SGSS Purchaser in the legal format and language of the delivered country. Any deviation to this will not be accepted. The Quality Control department will use the Material Safety Data Sheet (MSDS) to check the vendor products suitability for our use and for transport by our third party carriers (ADR Regulations).

2.7 Product Recyclability

For all products, the vendor agrees to implement a life cycle analysis of the products and contribute wherever possible to recycling and recovery.

2.8 Packaging

The vendor is requested to propose green packaging to SGSS. Virgin Raw Material should be avoided, with SGSS having an ambition to achieve 100% recyclable packaging and >30% recycled packaging content. Specific targets could be employed in line with an SLA.

SGSS have an obligation under the EU Packaging Directive to report packaging quantities to the local Environmental Agency. Upon request and where required vendors will support this reporting activity.

2.9 Product Safety

The vendor takes full responsibility for the safety outputs of his products, notably considering FEPA and FEICA regulations and will formally supply appropriate technical documentation and user instruction.

2.10 Site Safety Rules

Drivers shall strictly respect all Site Safety rules in force on SGSS sites. The rules below are **minimum** rules to be observed by all vehicle drivers, including contracted 3rd party drivers.

2.10i – Vehicle Drivers

- When entering the site drivers must wear high visibility jackets (further PPE may be required under site discretion – such as safety shoes in the yard).
- Drivers must register with the applicable goods reception, traffic department or security gate lodge providing organisation name, surname and nationality.
- All contractors entering the site will be informed of the site rules. These must be followed at all times.
- Certain Saint-Gobain sites operate under windows of restricted vehicle movements, where vehicles will only be allowed to move when the restricted time has passed; for example, during employee lunch time. Times are outlined among EHS rules where applicable.
- Drivers shall only travel in the correct direction within the site. Any reversing or taking short cuts to avoid the traffic management system is prohibited.
- Drivers shall strictly observe and comply with the maximum speed limits signposted on the site.
- Use of a mobile telephone whilst driving on site is strictly prohibited.
- Drivers of vehicles given permission to park on site shall refrain from parking in front of emergency exits and access doorways.
- In cases of large volume of personnel movement vehicles may be instructed to park and remain stationary until it is safe to continue.
- Drivers shall only smoke in the designated site smoking shelters.
- If the local site requires vehicles to be disabled the driver **MUST** comply with this instruction

2.10ii – Vehicle Unloading

The loading and unloading operations should be carried out in an area away from passing traffic, pedestrians and others not involved in the loading or unloading activity.

The following should also be considered:

- Before any unloading/ loading commences vehicles must be stationary with the engines disengaged.
- Drivers and any passengers should at all times follow any instructions of where their persons should be during the loading/ unloading operation.
- SGSS personnel are prohibited from getting into any third party vehicle, except when unloading is carried out with trans-pallet or forklift via a ramp or dock.
- When available, the vehicle has to go to the ramp or dock in order to facilitate heavy material handling.
- Loading or unloading activities should be carried out on ground that is flat, firm and free from potholes.
- Only SGSS pallets are to be handled or unloaded, handling of non SGSS pallets is not accepted.
- Goods must always be at the edge of the truck, correctly orientated in order to allow the take over by hand or by any mechanical means (e.g manual or electrical ‘transpallet’ or forklift).
- Any vehicles, trailers or containers that appear to be hazardous or dangerous will not be unloaded.
- Closure of the vehicle (doors, tailboard, tail lift and curtain) is fully under the vehicle driver’s responsibility, SGSS is not responsible for any accident or damage that may result from poor or incorrect vehicle closure.
- Vehicles moving from a loading or unloading position must be authorised by Saint-Gobain personnel.

QUALITY



3.1 Declaration

The vendor is solely responsible for the quality of samples and delivered products in accordance with the criteria defined in agreed technical documents including packaging and transport where applicable.

- The vendor has a quality system that is certified by an accredited third party (ISO 9001) or similar QMS. The vendor commits himself to uphold and improve its management system continuously in order to ensure the compliance with the quality requirements of SGSS at all times.
- The vendor shall ensure that SGSS have access at all reasonable times, after prior notice, to the vendor's premises to examine the compliance with the technical and quality processes, and the control of the manufacturing process at those premises. If as a result of the audits, corrective actions shall be found necessary by SGSS, the vendor shall initiate immediate measures to ensure the quality of the parts to be manufactured.
- If the vendor wishes to make any changes in the product/material or manufacturing process, the vendor must obtain prior written approval of SGSS and inform SGSS about the potential technical, logistical and commercial impact.
- The vendor commits himself to supply a corrective action plan in case of delivering non-conforming parts.
Refer to Chapter 6
- The target of the vendor is to deliver all products to the correct conformity at all times.
- The target of the vendor is to fulfill all orders respecting the order leadtime and quantities.

3.2 New Products/ Modifications

3.2i - Approval

All new products must be formally approved by SGSS Product Management and/ or R&D before manufacture and delivery. This includes all such information as:

- | | | |
|---|--|---|
| <ul style="list-style-type: none"> • Dimensions • Weight • Artwork • Labels and content • Carton documentation • Safety sheet | <ul style="list-style-type: none"> • Packaging <ul style="list-style-type: none"> - Design - Box structure - Material • For hazardous products
MSDS data sheets must be provided | <ul style="list-style-type: none"> • Technical data <ul style="list-style-type: none"> - Production Process Flow Chart - Inspection/ control plan |
|---|--|---|

3.2ii - Modification

For every new product, changed process, condition or location of production, validation is required by SGSS before delivery. The vendor commits himself to present technical and quality information and reports. No supply shall take place without such previous approval.

In the case of a request for modification on behalf of SGSS, the vendor must give:

- New part price offer
- Impact on tools and machines
- Time allowed for the application of the modification
- Stock of finished goods with their cost
- Stock of semi-finished goods with their cost
- Leadtime changes

3.2iii - Manufacturing changes

Prior to making any change in the properties, composition, construction, colour, processing, origin, source, (sub)vendor or labeling of the goods originally approved under the specification and whether or not such changes affect the ability of the goods to meet the specification, the vendor shall notify SGSS central purchasing team at least 6 months prior to any such change to obtain approval for the proposed change.

3.2vi Logistic Data Sheet

Where requested by the SGSS site, vendors are to complete the Logistic Volumetric datasheet (displayed in Appendix 3.8A) when supplying new products to SGSS. The datasheet should be filled in for any of the reasons listed below:

- New product introduction (NPI)
- New inner box dimensions and/ or weight
- New outer carton dimensions and/ or weight
- Modified sales carton quantity (inner box)
- Modified over packing quantity (outer box)

The vendor should ensure all Logistic Volumetric datasheets arrive before the delivery arrives at the SGSS site.

Appendix 3.8A displays an example of the Logistic Volumetric datasheet

3.3 Traceability Requirements

Traceability is ensured by the batch number, and, when technically possible, by part-marking. SGSS has the right to specify a maximum batch size.

The batch number must provide total traceability of parts or groups of parts at the vendor's expense (raw materials, supplied subcomponents, manufacturing processes, checks).

3.4 Stability and Expiry Dates

Upon request the vendor may be asked to provide with each delivery a Certificate of Analysis, dimensional report or other standard quality information.

The vendor clearly gives the shelf life of the product on each delivery/product.

All vendors will need to declare:

- The maximum shelf life of the product agreed with R&D, QC or Product Management during the qualification phase.
- In the absence of formal agreement the minimum shelf life requirement of SGSS is 12 months from delivery to the SGSS site. Any product failing this standard will be rejected at the vendor's expense.

Clearly show on the outside of any outer carton what the expiry date of the product is using the protocol day/month/year. This can be handwritten but must be clear and bold.

More generally, any particular constraints related to the use of the product whose physical and chemical characteristics may be affected by variations in the course of time shall be indicated by the vendor during the qualification phase.

3.5 Product Recalls

Product recalls are initiated by either SGSS or the vendor where a safety fault or non compliance with any regulation or specification has been identified with products that have already been sold and it is necessary to warn customers to return the products for a refund or replacement.

Product recalls can occur after the warranty period has expired in cases of safety.

All costs and expenses associated with product recalls will be claimed from the vendor.

3.6 Guarantee

It shall be a condition of the contract that the goods shall be of the best available design, of the best quality, material and workmanship, be without fault and conform in all respects with the Purchase Order, with the contract description and with any statements or undertakings made by the vendor, or his employees, or agents, prior to the making of the contract.

- If any or all of the goods supplied shall be defective upon delivery into SGSS or shall prove to be defective within 12 months of delivery to our customers, SGSS may call upon the vendor, without prejudice to the Company's other rights, to rectify, replace or reimburse at SGSS's option the defective goods.
- All rectification and replacement will be carried out at the vendor's own expense.
- All obligations in this guarantee shall further apply to any such rectified or replacement goods.
- This guarantee shall also apply to the benefit of SGSS customers or other users of the goods.

3.7 The Product Outer Package For Finished Goods

3.7i Overview

All product outer packaging should be selected to withstand handling, storage and transit as well as protect the product and prevent the loss of, and damage to, the sales unit within. If the packaging is visibly damaged or unsuitable, SGSS retains the right to refuse delivery at the vendor's own cost.

The vendor's identity, brand or affiliated logos will not appear on any primary, secondary or tertiary packaging delivered to an SGSS site without prior Purchaser approval.

3.7ii Definition

The product outer packaging is to be defined as the handling unit. The handling unit is the minimum level stored and shipped through the DC. Delivery could be refused if packaging quantities do not constitute the agreed handling unit.

Examples below:

- One outer box containing 25 grinding discs
- One outer box containing 8 x rolls
- One outer box containing 10 packs of 10 x assorted sandpaper sheets

3.7iii Label Requirements

All outer packaging should display a clear SGSS label with a minimum dimension of 100mm x 75mm and clearly showing the following information:

- SGSS Product SAP code
- Product description
- Product dimensions
- Quantity of sales units i.e
 - 1 if the outer packaging is sold as 1 box
 - 10 if the outer packaging contains 10 packs sold as individual units
- EAN barcodes – 13 characters
- For distribution products the following is to apply:
 - Brand
 - Appropriate Brand templates should be used
 - Unless agreed the labels must be positioned centrally on the front face of the product outer packaging.

Any questions regarding outer packaging and labels will be assessed and answered by the SGSS Product Manager.

Appendix 3.8B contains examples of SGSS outer packaging labels

3.8 Appendices

Appendix 3.8-A - Logistic volumetric data sheet



LOGISTIC VOLUMETRIC DATASHEET

For New Product Introductions and SKU Modifications

DATA TO KEY IN

Step

- 1 Fill in the width, length, height, weight and quantity of the Sales Unit
- 2 Fill in the width, length, height, weight and quantity of the Outer Carton (only when applicable, otherwise fill 0)

FIXED DATA

- 3 Standard required pallet dimensions, deviations need to be approved first.
Max. height 120 cm incl. pallet, 105 cm excl. pallet

CALCULATED DATA

- 4 Height and weight per piece based on weight sales unit / Qty in pieces sales unit.
Weight per pallet= (pieces per pallet * weight per piece) + 20 kg (= average weight of wooden pallet). Max. weight 800 kg.
Pallet quantity = number of sales units/outer cartons per pallet * number of pieces per sales unit / outer carton

SAP Product Code	66252834244	Description	115x2,2x22,23 A46S-BF27
------------------	-------------	-------------	-------------------------

	Width in cm	Length in cm	Height in cm	Weight in kg	Nber of cartons per layer	Nber of layers per pallet	Qty in pieces
Piece	4 16	4 16	4 0,08	4 0,0075			1
Sales Unit	1 16	1 16	1 8	1 0,75			1 100
Outer Carton	2 16	2 34	2 20	2 3,9			2 400
Pallet	3 80	3 120	3 105	4 245	4 15	4 5	4 30000

number of Sales Units or Outer Cartons within total length of pallet

number of Sales Units or Outer Cartons within total width of pallet

	3,5	3
	5,0	5
number of sales units/ outer cartons per layer		15



3.8 Appendices

Appendix 3.8-B - Outer packaging labels

LOGISTICS

4.1 Purchase Order

4.1.1 Purchase Order Introduction

A purchase order will be raised each time product is required by SGSS.

The orders are e-mailed depending on which method of communication the vendor has requested.

The purchase orders are transmitted as soon as they have been completed and saved within the SGSS ERP system.

4.1.2 SGSS Purchase Order Conditions

SGSS General Conditions of Purchase (GCP) are part of the Purchase Order. Acknowledgement of the order by the vendor implies full acceptance of the GCP.

With the exception of local legislation, GCP takes precedence over the general sales conditions of the vendor and if not differently mentioned or agreed are based on Incoterms 2020, in the DDP (Delivered Duty Paid) formulation.

ALL GENERAL CONDITIONS OF PURCHASE ARE AVAILABLE ON REQUEST.

4.1.3 Purchase Order Data

The purchase order quotes all of the following information and it is vital that vendors use this data when preparing the delivery notes:

- Delivery address
- Billing address
- Vendor address
- Query contact name & telephone number
- Date of order
- Order and line(s) number
- Saint-Gobain product code
- Vendors product code (if known)
- Article description and specification details
- Quantity / UOM
- Delivery Date, based on agreed lead time (i.e. when the delivery is expected to arrive in the SGSS site Goods In).
- Price
- Special instructions (where applicable)

4.1.4 Purchase Order Acknowledgement and Delivery Due Date

All vendors must issue an official order acknowledgement within 2 working days of receipt of the purchase order, unless otherwise stated on the PO text.

Any detail that deviates or is different from that stated in the purchase order must be highlighted to ensure that it is discussed and where necessary amended prior to the delivery receipt.

The vendor has no right to invoice a different price if they have not issued an official order acknowledgement. All such invoices will be disputed (see Chapter 5) all price queries are to be referred to local Purchasing Department.

Appendix 4.10-A displays an example of an SGSS Purchase Order

4.2 Delivery Notes

4.2.1 Delivery Note Conditions

All deliveries must be accompanied by a delivery note. If not, SGSS reserves the right to refuse the delivery.

Each order should have a separate delivery note (unless specifically agreed otherwise).

It is not permitted to attach the invoice to the delivery as a substitute for the delivery note.

(refer to Chapter 5 for an explanation on invoices)

4.2.2 Delivery Note Data

Each delivery note must include the following information:

- Purchase order number
- Purchase order line number
- SGSS product code
- Product description
- Line delivery quantity and unit of measure
- Vendor name
- Vendor address

Appendix 4.10 - B displays an example of a Delivery Note

ONEBOND adhesives, sealants and chemicals

4.2.3 Delivery note Data

Besides points mentioned at 4.2.2 the delivery note for ONEBOND products need to contain the following information:

- Hazardous goods UN class number (e.g. UN1139)
- Production batch number
- Production date / expiration date

For every first time shipment of Onebond products a TDS/SDS/VPI (Voluntary product information) should be sent to procuring site before actual delivery of goods.

Certificate of analysis needs to be provided per shipment.

Packaging

Onebond product shipments need to have the proper hazard / safety warnings / limited quantity indication and need to be separately stacked on pallets; 1 UPC/1 batch per pallet (no mixed pallet)

4.3 Palletised Deliveries DC/Warehouse

4.3.1 Declaration

When making a pallet delivery all rules outlined in this chapter are to be respected. The SGSS site reserves the right to refuse any attempted pallet delivery which does not conform.

For refused deliveries it is the responsibility of the vendor or 3rd party carrier to redeliver at their own expense with no impact on SGSS stock availability.

Failure to comply with any of the rules specified in this chapter without prior agreement from SGSS will be reported as a delivery failure (sent to the vendor via vendor Delivery Non Conformance report) and highlighted in the vendor's evaluation.



4.3.2 SGSS Goods-In Contact Details

The vendor or the carrier may be required to book a delivery slot with the SGSS site. Notification of 1 working day is needed prior to arrival of when goods are required. Your local Supply Chain or Purchasing contact can provide Goods In contact details upon request.

4.3.3 Delivery Schedule Requirements

Where requested by the SGSS receiving site, palletised deliveries must have a delivery slot pre-booked before any attempt to deliver is made. In such requirements a minimum of 24 hrs notice is needed.

When contacting the SGSS site for a delivery slot you must provide the following information:

- Which vendor the delivery is made on behalf of
- The carrier's name
- The SGSS purchase order number(s)
- Number of pallets
- It is not permitted for the carrier/ delivery driver to avoid adhering to a delivery slot by breaking a pallet into multiple cartons.

4.3.4 Pallet Design and Dimensions

All Distribution Centres and Warehouses within SGSS have racking configured to suit pallets of the specification set out in this section.

(Therefore all deliveries must fit the data specified):

- Maximum width: the goods must not overhang the edge of the pallet
- Other types of pallets can only be used based on the written approval of SGSS
- In case of 'customer assigned stocks' then a pallet 'type' will be confirmed in writing prior to commencement of deliveries.

Appendix 4.10 - Ci outlines the correct pallet type

Appendix 4.10 - Cii outlines an unacceptable pallet condition



4.3.5 Pallet Packaging Conditions

- The product, on each pallet, should be secured with transparent stretch wrap from the bottom of the pallet to the top and over the palletised goods, sufficient enough to prevent movement of goods during transit.
- Pallet boxes and black stretch wrap are ONLY permitted for such purposes as increased security and WITH prior SGSS agreement.
- For heavier, awkward, irregular pallet loads plastic strapping should be used.
- Steel strapping must NOT be used in any circumstances.
- All modifications to the stated methods of pallet packaging must be proposed in writing by the vendor to SGSS then agreed by the site contact.
- In such exceptional circumstances SGSS may request an alternative packaging type.

Appendix 4.10 - Di outlines the correct application for stretch wrapping the pallet

Appendix 4.10 - Dii outlines a suggested guide for preparing awkward or irregular pallets

4.3.6 Pallet Documentation and Labelling

Every delivery regardless of the number of pallets should contain a pack or delivery note as outlined in 4.2.

For all multiple pallet deliveries a Pallet Content List should be completed and attached to the top of each pallet containing the following information:

- Pallet number vs. total
- Destination address
- SGSS product code
- Quantity per pallet and unit of measure
- Purchase Order number
- The total weight of the pallet

Where the pallet weight exceeds 800kg a red warning sticker is to be applied to the pallet displaying the exact weight.

In cases of Vendor Consigned Stock the pallet delivery needs to be identified as vendor owned.

[Appendix 4.10 - Ei displays an example of a Pallet Content List](#)

[Appendix 4.10 - Eii displays a best practise example of a Heavy Pallet Label](#)

[Appendix 4.10 - F fragile handle with care label](#)

4.3.8 Pallet Build

When building pallets vendors must ensure the following rules:

- 1.2m is considered standard pallet height, unless agreed exceptions are applied (inc. pallet).
- Weight should be distributed evenly across the pallet
- Stacked products must be able to support the weight of combined loads, not contain boxes of 'air' which could cause collapse during transit
- Stacking of boxes and/ or wheels should be stacked evenly and aligned
- In the case of 'mixed pallets', where possible the cartons of the same part number must be located together.

4.3.7 Double Stacking Pallets

Double stacking of pallets maybe conducted purely with the agreement of the SGSS receiving site.

The following golden rules must be strictly adhered to:

- The lighter pallet is always to be stacked on the top
- The weight of the top pallet does not exceed 300 kilos (300kgs)
- The total weight of the stacked pallets does not exceed 1000 kilos (1000kgs)

All pallets containing products that are fragile must be marked 'NOT STACKABLE', using the label provided as outlined in Appendix 4.10 - F.

Vendors will be liable for all product damages as a result of double stacking using their own vehicle/ carrier.

It is also not permitted for the carrier to consolidate multiple pallet deliveries into one lift, with or without the removal of pallets.

4.3.9 Mixed Pallets

If the vendor delivers pallets where there is more than one product per pallet, then they must ensure the following:

- There is a clear segregation between such products
- It is clearly detailed within the delivery paperwork
- The pallet is clearly marked as 'MIXED PALLET' within the Pallet Contents List as outlined in section 4.3.6 and Appendix 4.10-H.

[Appendix 4.10 - Gi outlines the Pallet Build Specification](#)

[Appendix 4.10 - Gii displays best practise carton and label position](#)

4.3.10 Exceptions

The above guideline is our general standard requirement for accepting pallet deliveries into our DC's and warehouses. However we have identified exceptions to the above guide by product group. All exceptions need to be agreed in writing with the receiving DC/warehouse in advance.

i Bonded Abrasives (BA)

- Smaller pallets are accepted due to the bespoke size of the wheels but any larger pallets should be agreed with the SGSS site, in writing, before delivery.
- Pallets can be accepted weighing up to 1000Kg, they must be marked with the heavy pallet label in Appendix 4.10 - Eii.

Appendix 4.10 - I outlines the Bonded Abrasive Exceptions described above

ii Construction Products (CP)

For the purpose of machines three exceptions can be considered:

- Pallets are bespoke to fit the base area of the machine
- To optimise container cubic capacity machine pallets maybe stacked
- Pallet height may exceed 1.2m on the basis of machine height exceeding 1.2m.

iii Thin Wheels (TW)

If double stacking is permitted the following requirements are to be met:

- The pallets are separated or supported by a wooden board
- The weight of the top pallet does not exceed 300 kilos (300 kgs)
- The total weight of the stacked pallets does not exceed 1000 kilos (1000kgs).

Appendix 4.10 - J outlines the Thin Wheel Exceptions described above

iv Coated Abrasives (CA)

- Weight per pallet can exceed the 800kg limit in the case of Jumbo rolls where the maximum weight accepted will be 1200kg (heavy pallet label in Appendix 4.10 - Eii. should be applied)
- Overhang of pallets is permitted in the case of Jumbo rolls
- The overall height may reach 2.2 m in case of Segmented belts.

4.3.11 Containers

Exception can be made with pallet size and dimensions to optimise capacity when shipping by container. However all other points mentioned above in section 4.3 still apply, particularly documentation and mixed pallet build and segregation.

Key requirements:

- All containers are to be loaded by appropriately trained operators.
- All containers are to be loaded with appropriate distribution and the contents restrained/ supported with dunnage as necessary. Containers 'stuffed' in an unsafe or uneven manner which has the potential to cause spillage will incur charges for professional unloading as well as charges associated for damaged products.
- The delivery must be of a seaworthy standard, wrapped in plastic.
- For FCL (Full Container Loads) it is the vendor's responsibility to seal the container - not the driver.
- Extra care should be taken to ensure the contents of each pallet box have their labels/ product codes facing outwards enabling easy identification when processing the delivery.
- Delivery note should be on each pallet listing the contents.

Appendix 4.10 - Ki - displays an example of a correctly prepared pallet for shipping by container, complete with documentation attached

Appendix 4.10 - Kii - displays an example of an alternate method of segregating pallet contents

4.3.12 Pallet deliveries on Vans.

Any van that requires loading or unloading through the application of unsafe actions below will be refused.

Pallets can only be unloaded/ loaded via forklift or similar equipment - no manual 'handballing' off the bed of the vehicle will be permitted

4.4 Spare Parts

4.4.1 Mandatory Requirement

When making deliveries of spare parts strict guidelines outlined below must be adhered to:

- The item must not be delivered loose; items should always be packed in bags, blister packs or boxes.
- The item must contain minimum label requirements:
 - SGSS product code
 - Item description
 - Quantity
 - Unit of measure (pieces, pack)
- Package material is important so for fragile items they should be protected with extra packaging material.

Appendix 4.10 - Li - displays an example of a correct label for a Kit

Appendix 4.10 - Lii - displays an example of how individual components should be presented

4.4.2 Machine Kits

When requested by the SGSS Product Manager a variety of spare parts used for a common purpose maybe requested to be set up and delivered as a Kit.

A kit is defined as:

- 1 kit = 1 package
- All the components of the kit are packed in the same package and not in loose bags per piece.
- Hardware should always be packed in a small bag with the rules below to be followed:
 - If the kit contains one to 3 identical screws one additional screw must be added
 - If the kit contains more than 3 identical screws 2 additional screws must be added
 - Adapted labelling

4.5 Parcel Deliveries

4.5.1 Declaration

The packaging of goods shall be of a design, strength and size to guarantee optimum preservation and safety of the goods, persons and property, taking into account the nature of the goods, under normal foreseeable transportation and handling conditions.

All product packaging and labelling must comply with local law and regulations and SGSS's policy in terms of presentation, environment and where necessary bar coding. Any changes to the agreed methods of packaging made by the vendor have to either have been agreed by SGSS or, if the vendor advises an alternative, they must forward a request in writing to SGSS.

4.5.2 Parcel Safety

In order to harmonise EU country compliance with the Manual Handling Operations Regulations and Health and Safety Acts individual parcel weights should be limited to no more than 25Kg. Any carton with a weight greater than 25kg will need to be delivered on a pallet.

All packaging must respect any EU regulations in force to ensure the safety of goods during transportation and handling, and the safety of SGSS operators and end users.

4.5.3 Parcel Packaging Conditions

The following points should be adhered to when delivering parcels to SGSS:

- Parcels must NOT be sealed with staples. Instead suitable strength tape should be used.
- Appropriate parcel filler should be used to ensure the product remains undamaged in transit
- To optimise SGSS recycling activities the most environmentally friendly packaging should always be used.
- Avoid virgin raw material
- 100% recyclable packaging
- >30% of recycled or bio-sourced content on packaging

[Appendix 4.10 Mi - Parcel/Carton Packing - Shredded Card/Paper](#)

4.5.4 Multi Carton Deliveries

Breaking up of pallets to multiple cartons to avoid booking in slots will not be accepted.

4.6 Delivery Receipt Problems

4.6.1 Goods In Declaration

All deliveries whether pallets, parcels or otherwise must be in good, undamaged condition when received at the SGSS site.

In all cases where there could be a dispute, the SGSS site or a 3rd party receiving agent is responsible for noting any discrepancies on the carrier's paperwork, as well as following up with the appropriate discrepancy form (Vendor Delivery Non Conformance form).

In line with the General Conditions of Purchase, SGSS reserves the right to notify the vendor, at any time and by any available means (email, etc.), of the defective performance, lack of performance, or non-performance of its contractual obligations, or of any loss, damage or non-conformity of goods observed upon removal of packaging or during subsequent inspections, even if the corresponding invoices have been partially or fully paid.

4.6.2 Delivery Failure Confirmations

All delivery failures will be logged by the site at Goods Receiving. In using the SGSS Vendor Delivery Non Conformance form (VNC). This will be forwarded to the offending vendor within 2 working days by your SGSS purchasing contact.

It is mandatory for all vendors to respond with corrective action as instructed on the VNC form.

(Please refer to Vendor Evaluation Chapter 6)

4.6.3 Hazard/ Safety Warnings

Hazard or safety warnings on the goods are the responsibility of the vendors without exception. Any delivery deemed to be unsafe will not be unloaded.

4.6.4 Shortages/ Damages

Delivery shortages and damages will be noted on the carrier's paperwork at the time of receipt where possible. Any complaint will be forwarded to both vendor and carrier within 2 working days of receipt of the product after it is accepted on site (using the Vendor Delivery Non Conformance form).

4.6.5 Delivery Failure Definitions

Code	Delivery Failure Description	Code	Delivery Failure Description
A1	Delivery Failure Description	D1	Damaged goods
A2	Pallet deliveries not booked in	D2	Incorrect packaging (including labels, bar codes)
A3	Failed delivery slot	D3	Incorrect quantity
B1	Early delivery - not agreed	D4	Incorrect pallet type
	No delivery paperwork	E1	Product stating incorrect SGSS part number
B2	Incorrect paperwork (doesn't match physical consignment, insufficient data to process delivery)	E2	Product not stating SGSS part number
C1	Damaged packaging	F1	Consignment or load unsafe
C2	Incorrect product	XX	Multiple reasons from the above list

Appendix 6.9 - A refers to an example of Vendor Non Conformance report

4.7 Vendor Returns

Deliveries which do not conform to the agreed standards, will be rejected and quarantined by SGSS pending further action. An official claim will be raised with the decision to return to the vendor.

Cost responsibility:

At its discretion, SGSS may request either replacement or repair of the goods at the vendor's expense.

The vendor shall, at his own expense, remove rejected goods within eight (8) calendar days of the notification of the rejection via the VNC. After that period has elapsed, SGSS may remove the goods by any mean at its discretion, at the expense and risk of the vendor.

These costs include but are not limited to:

- All transportation costs
- Customs costs
- Product
- Packing
- Labelling
- All other costs not outlined in regards to product or transportation
- An administration fee of €100.

4.8 Reimbursement Of Costs For Re-Work/Re-Pack

SGSS reserves the right to invoice in the event of non conforming products that require correction but are unable to be returned to the vendor in cases where constraints are in place due to time, distance or freight cost.

This corrective rework action will be broken down as follows:

- Labour
- Management and Operative charges
- Materials/ Packaging/ Labelling
- Associated transport cost of such materials

4.9 Scrap

In the event of constraints not permitting a return to vendor or possibility of product rework, SGSS reserves the right to invoice the vendor for the destruction and disposal of any non-conforming product.

4. 10 Appendices

4.10 - A - Purchase Order - Good Example



SAINT-GOBAIN ABRASIVES LTD DOXEY ROAD ST16 1EA STAFFORD United Kingdom VAT Registration no:GB577820309	PURCHASE ORDER Page:1 of 2
Conflans V3040 RUE DE L'AMBASSADEUR 78702 CONFLANS-SAINT-E-HONORINE France Telephone: (33) 1 34 90 40 Fax: (33) 1 39 19 89 56	PO Number: 8000576565 2 Date: 10.01.2014 Buyer: Matthew Hoar Telephone: 00 44 (0) 1785 279 546 5 Buyer Fax:

Item	Material	Quantity	UOM	Del.Date	Unit Price	Tax%	Total Price in
					Freight (%/value)	Disc(%/value)	EUR
0010	63642561006 1	60	PC	04.02.2014	178,39/100 PC	20,00-	107,03
	BNR BNL 50x1800 R473 NOR P120			3	-/-	-/-	
0020	66261023492	2	PC	06.02.2014	14.227,40/100 PC	20,00-	284,55
	RTH RL 300x50M R817 NOR P40 EU				-/-	-/-	
0030	66261049838	3	PC	28.02.2014	14.635,94/100 PC	20,00-	439,08
	RTH RL 300x50M R976 NOR P120				-/-	-/-	
Grand Total in EUR							830,66

Invoice to be sent to the following address:
 Saint-Gobain Abrasives Ltd
 Finance SSC, East Leake.
 LE12 6JU Loughborough, Leics. United Kingdom

Delivery Address:
 DC Stafford-SAINT-GOBAIN ABRASIVES UK LTD.
 Doxey Road, 4
 ST16 1EA, Stafford United Kingdom

Payment Terms: INTC - Interco payment within a region
Shipment Instructions: ** -
Incoterms: EXW - EXW Ex Works

1 SGSS Product Code

2 SGSS PO Number

3 Requested delivery date to SGSS site Goods
 In - NOT date of vendor despatch, regardless of
 incoterm

4 Delivery Address

5 SGSS Contact

4.10 - B Delivery Note - Good Example

LOGO

Page 1 of 1

REMIT TO:
IBAN CODE:
SWIFT/SORT CODE:
ACCOUNT NO:

Customer Service Call:

SHIP TO: ①
SAINT-GOBAIN ABRASIVES LTD
BM Warehouse n°2
Doxey Road
STAFFORD
ST16 1EA
GRANDE BRETAGNE

SHIP FROM: ④
SAINT-GOBAIN ABRASIFS
RUE DE L'AMBASSADEUR
F-78702 CONFLANS-SAINTE-HONORINE

FREIGHT TERMS: Best Way - SGA
NET WEIGHT: 8,553.60 G
GROSS WEIGHT: 8,553.60 G
NO OF BOXES:
INCOTERMS: EXW Ex Works
CONFLans

SHIP DATE: 23.01.2014 ⑤
ORDER DATE: 10.01.2014
ORDER NO: PO8000576565 ⑥
DELIVERY NO: 58656164
YOUR ORDER REF: ⑦

TRANSPORT MODE:
CARRIER:

/ PACKING LIST /				
LINE	PART NUMBER AND PRODUCT DESCRIPTION	ORDERED	SHIPPED	BACKORDER
0010 ②	63642561006 ③ 3157625871472 ⑨ BNR BNL 50X1800 R473 NOR P120 Net Weight: 142,56 G	60 PC	60 PC ⑧	0 PC ⑩
SOLD TO: SAINT-GOBAIN ABRASIVES LTD BM Warehouse n°2 Doxey Road ST16 1EA Stafford				

Our general terms and conditions of sale apply to all items and agreements on this document. A printed copy will be sent to you upon request.
The goods referred to on this invoice remain the property of Saint-Gobain Abrasifs until paid for in full.

① Delivery address

② Delivery line number

③ SGSS Part number

④ Vendor details

⑤ PO order date

⑥ SGSS PO number

⑦ Vendor delivery number

⑧ Line Quantity

⑨ SGSS description

⑩ Outstanding balance

4.10 - Ci - Pallet Type

Euro Pallet 800 x 1200mm

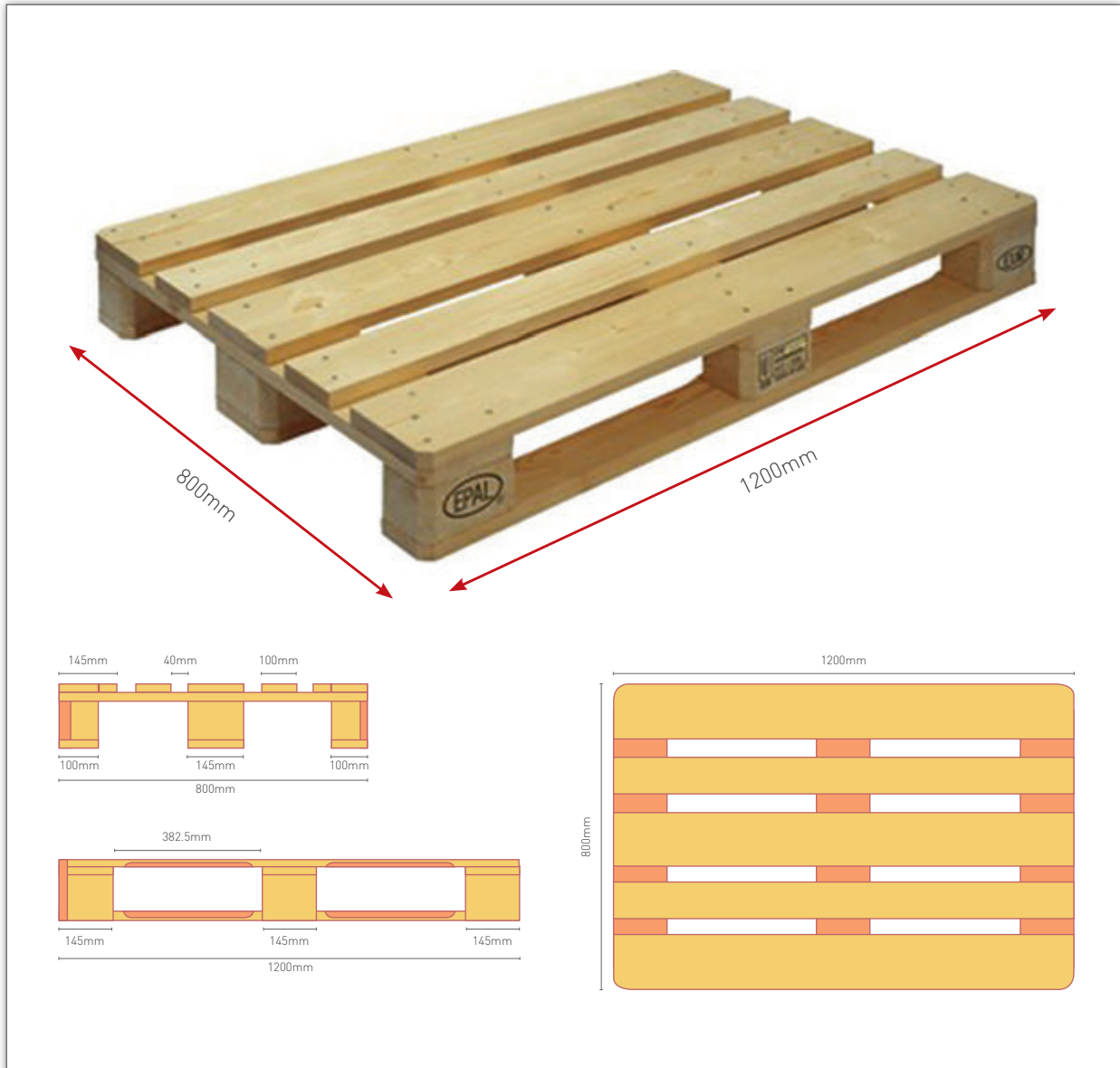

4.10 - Cii - Unacceptable Pallets

- Vendors must have in place an inspection program, with all pallets inspected before loading and be in a good, serviceable condition.
- Unacceptable pallet damage including but is not limited to the following

- 1 Broken Base Boards
- 2 Stretch Wrap Remnants
- 3 Old Incorrect Labels
- 4 Loose, Misaligned or Damaged Corner Blocks
- 5 Protruding Nails
- 6 Broken Top Boards
- 7 Contamination
- 8 Loose or Misaligned Boards
- 9 Multiple Small Splits

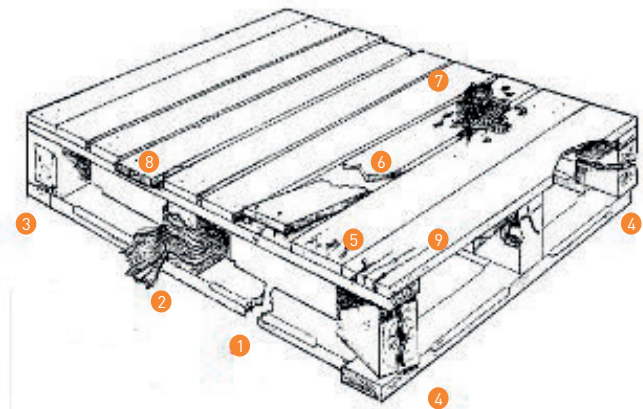

4.10 - Di - Pallet Build and Stretch Wrapping

Quality stretch wrapping will help to secure the goods onto the pallet. This will prevent damage to the product and people handling the pallet by preventing unwanted movement or collapse.

Below is a suggested guide:

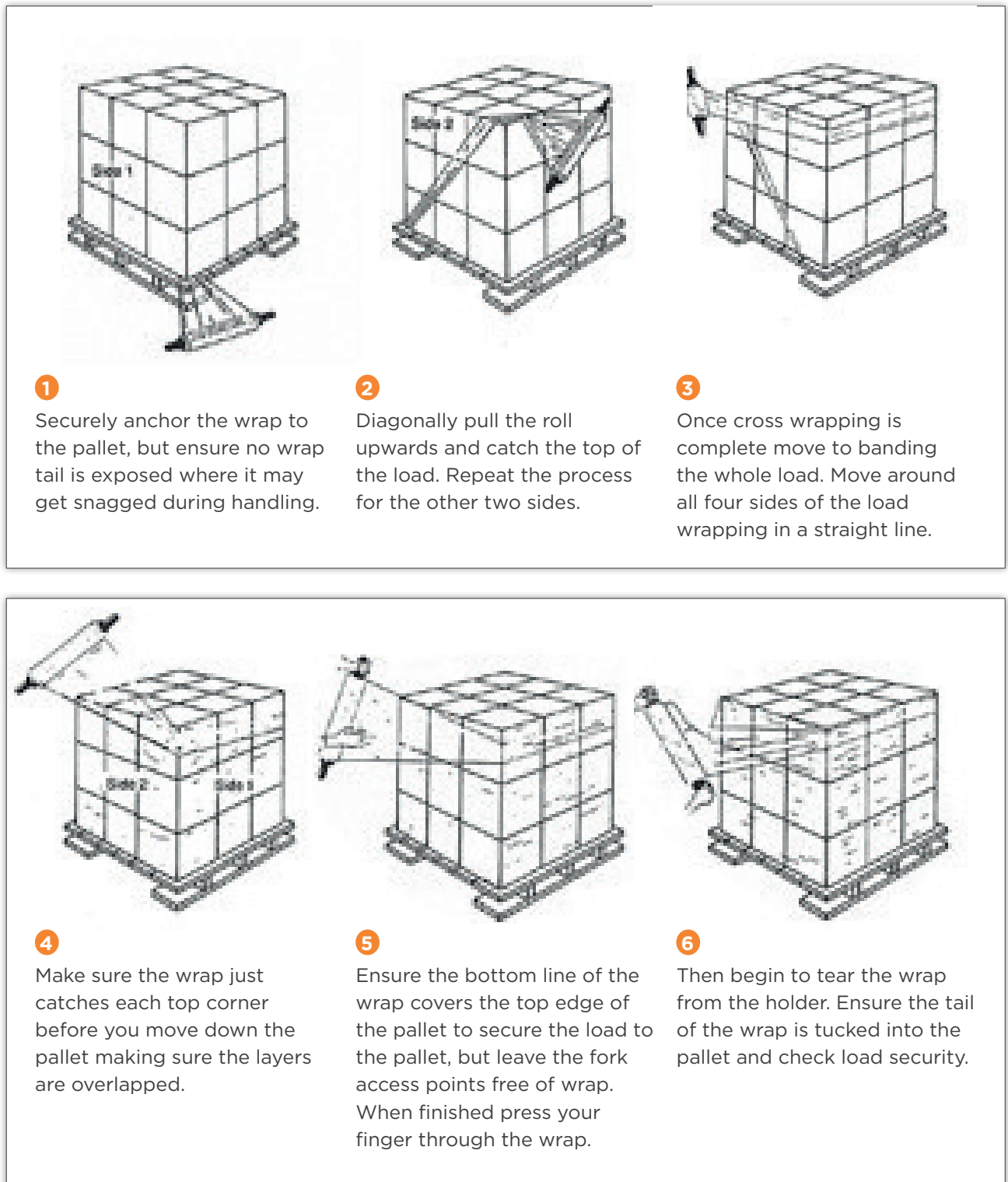

1 Securely anchor the wrap to the pallet, but ensure no wrap tail is exposed where it may get snagged during handling.

2 Diagonally pull the roll upwards and catch the top of the load. Repeat the process for the other two sides.

3 Once cross wrapping is complete move to banding the whole load. Move around all four sides of the load wrapping in a straight line.

4 Make sure the wrap just catches each top corner before you move down the pallet making sure the layers are overlapped.

5 Ensure the bottom line of the wrap covers the top edge of the pallet to secure the load to the pallet, but leave the fork access points free of wrap. When finished press your finger through the wrap.

6 Then begin to tear the wrap from the holder. Ensure the tail of the wrap is tucked into the pallet and check load security.

4.10 - Dii - Irregular Palletised Loads

Awkward, Irregular and Upright Loads

Awkward, irregular and some upright loads may require plastic banding:

- Edge and corner banding protection must be used
- Banding must not be over tightened where damage to the pallet may occur
- Top boarding is the most secure method of banding as shown below. Where this is not possible banding edge protection must be used
- Banding should be used only in vertical alignment
- Heavy loose items must be contained within a suitable frame to prevent collapse.

Below is a suggested guide:

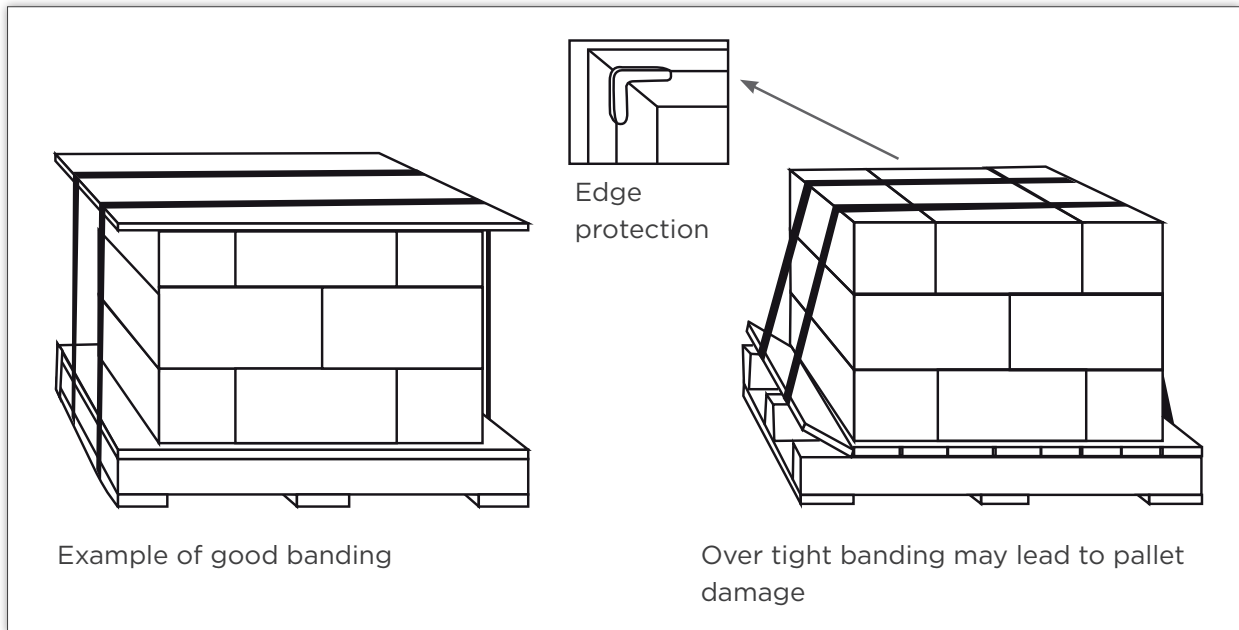

4.10 - Ei - Pallet Contents List

FRAGILE			
SAINT GOBAIN ABRASIVES LTD BM WAREHOUSE No.2 DOXEY ROAD STAFFORD ST 16 1 EA UNITED KINGDOM		pallet Nr: 1/12 weight: 385 kg. size of pallet: 100X80X85 cm.	
pallet content:			
position number	sup code	PO No.	quantity disp.
1	66252829241	8000362837	275
32	66252829441	8000362837	2250
11	66282944558	8000362837	8000
14	69936645875	8000362837	5000
7	69934475120	8000362837	250
2	22458668214	8000362837	500
24	66225562214	8000362837	4875
33	66252829447	8000362837	5000
SAINT GOBAIN ABRASIVES HANDLE WITH CARE DO NOT STACK!!!!			

4.10 - Eii - Heavy Pallet Label

CAUTION Heavy!
Over 800kgs

4.10 - F - Fragile Do Not Stack Label

FRAGILE	
HANDLE WITH CARE DO NOT STACK!!!	
FRAGILE	
PALLET NR:	
GROSSWEIGHT:	KG.

4.10 - Gi - Pallet Build Specification

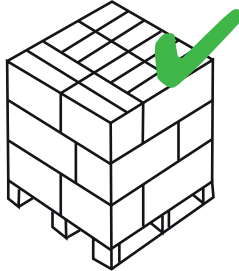
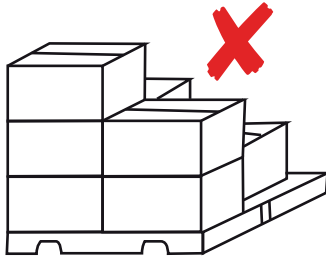
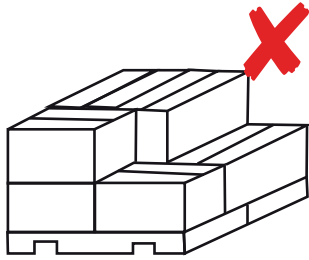
 <p>Acceptable - boxes are interlocked by varying box load pattern.</p>	 <p>Pyramid stacking will result in load being rejected.</p>	 <p>Uneven stacking and poor distribution of weight will result in the load being rejected.</p>
--	---	--

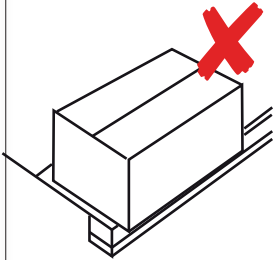
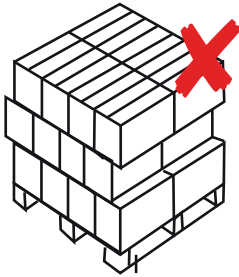
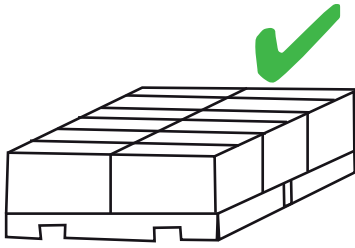
 <p>Pallets with boxes overhanging pallet will be rejected.</p>	 <p>Poorly stacked or misaligned boxes on a pallet will result in the load being rejected.</p>	 <p>Acceptable - Heavy load with reduced height and even weight distribution.</p>
---	--	--

NB. All Pallets will be checked for the following:

- Pallet Height
- Pallet Weight
- Lean or Overhang
- Stretch Wrap
- Pallet Quality

If the pallet fails any of the above, this may result in the delivery being refused.

4.10 - Gii - Pallet Build - Carton and Label Position



4.10 - H -Mixed Pallets

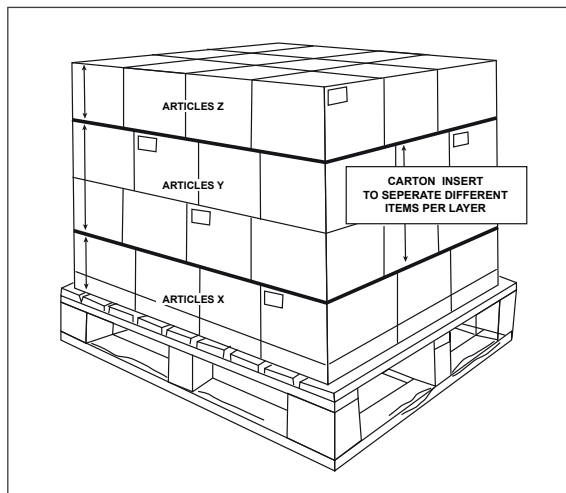

4.10 - I - Exceptions - BA Products



Example of good vertical pallet packing.



Example of good horizontal pallet packing.

4.10 - J - Exceptions - TW Products



Example of wooden board to be used when double stacking.



Use wooden board to separate the pallets.

Appendix 4.10 - Ki - Displays an example of a correctly prepared pallet for shipping by container, complete with documentation attached



Appendix 4.10 - Kii - Displays an example of an alternate method of segregating pallet contents



example of segregation for mixed pallets with different layer build quantities.

Appendix 4.10 - Li - Displays an example of a correct label for a Kit

Logo "Norton Clipper"

EAN Code



Material number

PO number

Material description in 3 languages

Appendix 4.10 - Lii - Displays an example of individual components forming a Kit

BEFORE - 3 ITEMS



AFTER - 1 ITEM



BEFORE - 5 ITEMS



AFTER - 1 ITEM



4.10 -Mi - Parcel/Carton Packing - Shredded Card/Paper

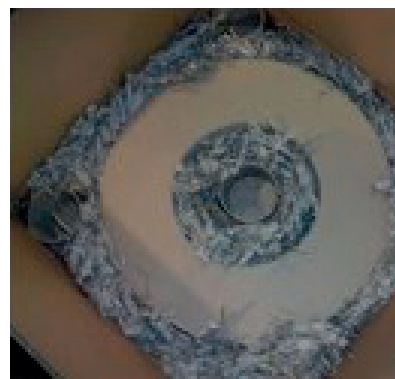

Carton Packing using shredded card, ensuring cavities around the periphery of the product.

FINANCE



5.1 Pricing

5.1.1 - RFQ

The vendor must send its technical/economic offer directly in the SGSS Request For Quotation (RFQ) format sent by SGSS within the time specified. All items in the RFQ format should be answered.

In case of lack of technical information and/or delay, the vendor shall inform the SGSS technical contact or buyer sufficiently in advance.

By answering the RFQ, the vendor commits himself in case of selection to supply SGSS for a minimum duration of 5 years and 10 years for spare parts if applicable. This duration can be given at the vendor's request during the component development phase.

Capacity: Proposed tools associated must have capacity to deliver the full potential quantities (daily and life-long) of the volumes of the SGSS RFQ.

Prices are exclusive of Value Added Tax but inclusive of all other taxes, duties and all other charges.

Unless otherwise agreed in writing the price shall include payment for all tools, patterns, dies, molds, jigs, fixtures, drawings, data, artwork or other material created under this contract.

The price is inclusive of all fees, royalties and charges in respect of all artwork, data, designs, drawings, specifications, tooling, goods or other materials created by the vendor.

SGSS will be allowed all discounts normally offered by the vendor for bulk purchases, prompt payment and other reductions.

5.1.2 - Order/ Contract

Unless otherwise agreed in writing the prices shown in the Purchase Order are firm and fixed for the duration of the contract. Neither variation in the price nor extra charges will be accepted by SGSS. Where no price is shown the order is conditional upon the price being acceptable to SGSS.

The price will include all necessary packaging, shipping and delivery costs.

The SGSS General Purchasing Conditions (sent with each order) will be applied unless a particular agreement has been negotiated and signed with the SGSS buyer. General conditions can be provided on request.

5.2 Invoicing

Details of invoicing are maintained with the General Conditions of Purchase.

As a reminder, invoices must NOT be sent to the SGSS site, but the billing address as defined within the Purchase Order. As a minimum invoices must include the same information as the delivery note and must state in all instances the Purchase Order number and VAT registration number-specific details are contained within the General Conditions of Purchase.

SGSS operates using automated invoice matching which brings vendor invoices and goods received information together via the 10 digit SGSS Purchase Order number. SGSS cannot match and therefore pay invoices if the SGSS PO is not stated. In addition SGSS cannot process payment if vendor invoices consolidate multiple PO's - there can only be one SGSS Purchase Order number quoted per invoice.

Failure to comply with this request will result in payment delays and in cases of manual processing SGSS reserves the right to charge an administration cost of €100.

5.1.3 - Changes

All vendors will agree invoiced cost prices with the buyer, which shall not be increased for a minimum of 12 months after agreement.

Any price variations must be agreed in writing with SGSS, but in any event will not be implemented until at least 6 months from such agreement.

In case of transfer of the SGSS production or logistic site, all the agreed conditions will remain unchanged (except packaging and transport costs to be eventually re-discussed).

Volume estimations indicated in the RFQ are not a minimum commitment from SGSS and are subject to market variations. The price is only related to minimum order batch given in the offer of the vendor.

Reminder: Vendors must not include suffixes, prefixes, hyphens or spaces. Quoting the correct SGSS Purchase Order number on both the delivery note and invoice is crucial in enabling SGSS to quickly match and pass a vendor invoice for payment.

Invoices sent to SGSS must not arrive earlier than the date the goods are delivered.

Similarly, invoices must not be dated prior to delivery, unless agreed with the appropriate SGSS Purchasing Manager in such cases of part payment.

Payment of the Price (or any part thereof) shall not constitute any admission by SGSS as to the performance by the vendor of its obligations under the contract.

SGSS reserves the right to withhold payment in respect of disputed invoices.

SGSS reserves the right to deduct any monies due or to become due from the vendor to SGSS from any monies due or to become due from SGSS to the vendor.

5.3 Invoice Discrepancies

SGSS may withhold payment in cases of disputed invoices, notifying the vendor of any such dispute except in cases of quality complaints where SGSS may notify the vendor at any time up to the due date of the invoice, but will seek to notify within 14 calendar days of receipt. SGSS could withhold payment for such reasons as listed below:

- a) Short delivery/ Over delivery
- b) Incorrect Prices
- c) No Record of Delivered Goods/ Services
- d) Damages
- e) Delivery non conformance

In any such case a Vendor Non Conformance ticket will be raised by the receiving SGSS site. Vendors should present queries in writing or using e-mail giving an outline summary of:

- The PO and subsequent invoice in dispute
- The type(s) of query (i.e. pricing, unpaid invoices, proof of delivery)
- The total value in dispute

5.4 Payment

All vendors must conform to agreed terms with SGSS.

Any variation, other than for BACS payments (Bankers' Automated Clearing Services) must be approved by SGSS's local Finance Director.

5.5 Appendix

A good invoice:

COPY Page 1 of 1

LOGO

BILLING DATE : 23.01.2014
INVOICE NO : 910625463
SALES ORDER NO : 8000576565
CUSTOMER NO : CB3005
SALES PERSON :
YOUR ORDER REF :
CURRENCY : EUR

REMIT TO:
IBAN CODE:
SWIFTSORT CODE:
ACCOUNT NO:

Customer Service Call:

SAINT-GOBAIN ABRASIVES UK
 DOXEY ROAD
 STAFFORD-
 Staffordshire
 ST16 1EA
 UNITED KINGDOM

YOUR VAT NO: GB577820309

/ INVOICE /				
LINE	PART NUMBER AND PRODUCT DESCRIPTION	QUANTITY	UNIT PRICE	TOTAL
0010	63642561006 EAN NO: 3157625871472 BNR BNL 50X1800 R473 NOR P120 FINISHED GOODS COATED POLYESTER BELTS, NARROW Origin of Goods: France; Commodity No: 68051000 Delivery No & Ship Date: 0058656164, 23.01.2014	60 PC		
NET SALES:				107.03
VAT (0.00 %):				0.00
INVOICE TOTAL:				107.03

PAYMENT TERMS: Interco payment within a region
PAYMENT ADDRESS : SAINT-GOBAIN ABRASIFS BP 60009 60477 COMPIEGNECEDEX FRANCE
DUE DATE: 15.02.2014
INCOTERMS: EXW Ex Works

Lump sum allowance of 40 EUR for recovery costs in accordance with Articles L.441-3 and L.441-4 of the commercial Code
 Late payment are subject to penalties, from the due date to the actual date of payment. The penalty interest rate is equal to three times the legal interest rate.

INVOICE CERTIFIED TRUE AND SINCERE ACCORDING TO OUR LEDGERS.
 SAINT-GOBAIN ABRASIFS BY PROCURATION

VAT EXEMPTED, ARTICLE 262 TER-I OF CGI

SOLD TO:
 SAINT-GOBAIN ABRASIVES LTD
 BM Warehouse n°2
 Doxey Road
 STAFFORD
 ST16 1EA
 UNITED KINGDOM

SHIP TO:
 SAINT-GOBAIN ABRASIVES LTD
 BM Warehouse n°2
 Doxey Road
 STAFFORD
 ST16 1EA
 UNITED KINGDOM

Our general terms and conditions of sale apply to all items and agreements on this document. A printed copy will be sent to you upon request.
 The goods referred to on this invoice remain the property of Saint-Gobain Abrasifs until paid for in full.

SAINT-GOBAIN ABRASIFS
 Service Commercial Export - Fax +33 (0)1 39 19 76 24
 Siège Social : Rue de l'Ambassadeur - B.P. 8 - F78702 Conflans Cedex France
 Tél. +33 (0) 1 34 90 40 00 - Fax +33 (0)1 39 19 89 56
 S.A. au capital de 18 829 456 euros - SIRET number 66980124300017 RCS Versailles - N° TVA FR47669801243

- 1 Bill to address
- 2 Account details for payment
- 3 Customer order reference (i.e. SGSS order reference)
- 4 Currency
- 5 Vendor Part number

- 6 Customer Part details (i.e. SGSS part code and description)
- 7 Quantity
- 8 Line Price
- 9 Shipping Address
- 10 Vendor details: address & VAT number

VENDOR PERFORMANCE



Each delivery received at the SGSS Site will be subjected to an assessment on Logistic, Quality and Technical specification in respect of this Vendor Manual and/ or our Agreement.

6.1 Vendor Declaration

All vendors, by acknowledging the PO, agree to adhere to the rules and guidelines set out in this Vendor Manual. Unless agreed in writing all delivery non-compliance will be considered and recorded as a Vendor Delivery Non-Conformance.

Each vendor will continuously be assessed regarding their performance using a Vendor Performance Indicator (VPI).

6.2 Purchase Order Acknowledgment

PO acknowledgment is mandatory, with a response to the SGSS Supply Chain/ Purchasing contact required within 2 working days. PO acknowledgment will be analysed based on response lead time.

6.3 Vendor On Time Delivery Performance

The vendor will deliver the goods on the delivery date and at the delivery location specified on the Purchase Order.

SGSS will record each Purchase Order line and compare the Delivery Date, which is stated on our Purchase Order document, with the Actual Date of Receipt of the products into the SGSS receiving site.

SGSS will continuously monitor delivery adherence to the defined Delivery Date, producing an OTIF (On time in full) measure for each vendor aswell as a second axis on vendor lateness, which captures the average days late for failed OTIF deliveries per vendor.

Early deliveries (a delivery date more than 5 days earlier from the acknowledged delivery date) must be agreed with your local SGSS contact.

Reference:

“Delivery Date” is stated on our Purchase Order as the date that the products are requested to arrive at the SGSS receiving site and is used to report the expected delivery date onto our site. (Note – this includes transport leadtime between the site of the vendor and SGSS, even when the incoterm is EXW or FOB)

- The Delivery Date shall reflect our Requested Date based on the agreed lead time of the planned delivery, until PO Acknowledgement where it will be considered confirmed.
- All changes to delivery dates will be reflected in SAP by SGSS with an acknowledgment reference code for traceability, and will be considered as a confirmed delivery date.

6.4 Vendor Pro-Active Communication

In order to optimize our stock availability and continuously improve service to customers Saint-Gobain Surface Solutions could ask to reschedule the confirmed delivery date on the Purchase Order.

Each week all vendors will be in receipt of an email titled ‘Weekly PO Rescheduling’ containing a spreadsheet listing PO lines that require an action from the vendor, as follows:

- Reschedule In: SGSS require the vendor to expedite the PO line delivery.
- Reschedule Out: SGSS require the vendor to postpone the PO line delivery.

The action required is indicated by a priority code:

Receiving Plant	Priority Code	PO #	PO line #	Open PO Qty	Material	ABC	Delivery Date	Rescheduling Date	Rescheduling (In Days)	Order Acknowledgement	External Vendor Ackn.	Production Order #	HSP Controller	Basic Finish Date	Production Order Qty	Nb Open Purchase Order	Nb Open ProdOrder	New Date	Coverage In Days
9302	DC Born	1	Rush Delivery - Stock out	8001002052	30	100	69078663924	52_A5M_20x28xM4M_4Z8W24A60R7V35.	F	06/06/2020	24/05/2020	-74		RBC	0	1	0		-45.00
9302	DC Born	1	Rush Delivery - Stock out	8001002052	10	100	61463626001	90_IB24_1/2"x1"x4"_BW10A32015V.	B	06/06/2020	20/05/2020	-78		RBC	0	7	0		-2.55

PACT Priority Code definitions

Priority Code	Definition
0	Rush Delivery - out of stock + date in the past
1	Rush Delivery - Stock out
2	Rush Delivery - Low stock
3	PO date in the past - New confirmation needed
4	Postpone delivery to required date
5	Cancel production if possible and confirm

The vendor is required to complete this file and return to the requesting SGSS site no later than **48 hours**.

The SGSS site will then update SAP directly with the revised delivery dates, and also an acknowledgment code for traceability.

This is a key lever for improving customer satisfaction for SGSS, and **consequently will be considered as an axis for Vendor Performance and Review**, expanded further in section 6.7.

6.5 Logistic Non-Conformance

The delivery will be assessed based on 6 areas of core competence:

- A. Pallet delivery booking compliance (SGSS site specific)
- B. Delivery paperwork compliance
- C. Damages
- D. Physical delivery compliance (pallet type, quantities, packaging, labelling etc)
- E. SGSS product code accuracy
- F. Delivery safety compliance
- X. Multiple reasons

Followed by a level of priority: - Level of Non Conformance

Observation

Delivery booked in with no immediate or significant non conformance. Vendor issued a monthly summary of observations.

Warning

Delivery booked in after failure workaround from SGSS personnel.

Rejection

Delivery unable to be booked in, with the delivery not unloaded or moved to quarantine. This requires immediate response and action from the vendor. (With the 'Vendor Response' section completed.)

In the event of a delivery non conformance being recorded by the site Goods Receiving team the following procedure will be initiated:

- The failure will be recorded and forwarded, via e-mail, to the vendor on a 'Vendor Delivery Non Conformance' (VNC) form (see example within appendix 6.9) within 2 working days of delivery receipt.
- The vendor will be given response and action deadlines based on VNC priority: - Level of Non Conformance.

Observation

No response required, will be reported back to the vendor on a monthly basis.

Warning

Response required within 5 working days, where statement of what actions will be taken to correct the issue and what the planned timings will be.

Rejection

Immediate response (1 working day) from the vendor with corrective action and resolution.

6.6 Quality and Technical Non-Conformance

It is in the interest of both SGSS and the vendor, to identify as quickly as possible any non-conforming products.

Vendors are expected to notify SGSS immediately if non-conforming products have been detected in their production lines and/ or final inspection before shipping to SGSS sites. If requested by SGSS, the vendor must send samples of such non-conforming items for evaluation.

In the event of a non-conforming product being identified at SGSS Goods Receiving inspection, during storage, production, at the customer or final end user, SGSS will inform the vendor through an official Non-Conformance report.

For any defective parts found in deliveries or when being assembled during the pre-run and/ or production run within the SGSS site, the vendor at their own expense must identify and quantify the total number of suspect products received by SGSS without delay. If this identification and quantifying action is conducted by SGSS or an external party recruited by SGSS after notification the vendor will pay the costs incurred.

The cost of shipping, inspection, testing, handling or administrative tasks associated to determine the potential acceptability of such suspect non-conforming product will be charged to the vendor.

Depending on the type and severity of non-conformance, products will either be scrapped or reworked by the vendor and if the circumstances require, the vendor may be asked to ship replacement products.

On critical or repetitive issues, it is important that the vendor starts with a problem solving process upon notification and implement immediately the appropriate actions to contain the problem and avoid any further disturbances in production and to avoid potential quality hazards.

When a customer quality complaint is opened and if the anomaly is in relation to the technical quality of the product, the complaint cost is at the charge of the vendor. In that case a refund will be requested from the vendor by SGSS.

When a product technical non-conformance is raised and issued to the vendor, the vendor will react in accordance with the following timeline from the date of SGSS raising the technical non-conformance:

- 1) 1 Working Day: Acknowledgement to SGSS and to open an 8D+5W report (see appendix 6.9B).
- 2) 2 Working Days: Non-conformance containment with the immediate actions fully implemented and reported to SGSS.
- 3) 10 working days: Root cause analysis completed for the non-conforming occurrence, permanent corrective actions in place with measures implemented to capture future detection (8D+5W completed).

6.6 i - Summary of Vendor Responsibilities

- The vendor is responsible for shipping only product that meets SGSS and / or European Standard specifications.
- The vendor is responsible for responding to and processing a Non-Conformance request for products deemed to be of a non-conforming standard.
- The vendor is responsible to open and complete an 8D report and implement subsequent improvements to avoid reoccurrence.
- The vendor has to provide the completed 8D report, outlining actions implemented, performance of measures introduced and how the vendor will sustain the improvements.
- The vendor is responsible for all SGSS losses due to the non-conforming quality of his products (to include costs below, but not exhaustive):
 - SGSS customer refund
 - SGSS administration costs
 - SGSS inspection and testing costs
 - Additional transport costs
 - Loss of production in SGSS plants
- The vendor is responsible for the full traceability of his product based on the SGSS requirements outlined in this Vendor Manual.

6.7 SGSS Customer Complaints

In the event that SGSS is given notice of any claim, whether actual or threatened, concerning some or all of the products, it will inform the vendor as soon as practicable of the nature of such claim. The vendor will, within 10 working days of a request by SGSS, inspect the said goods, whether at SGSS's or third party's premises and prepare and submit to SGSS written report of its findings within the following 10 working days. In addition, and if SGSS or its customer so requests, it will reimburse SGSS the cost of instructing an industry independent expert to inspect the respective goods to give an opinion in relation to their conformity with the contract. Neither party shall be bound by any report or opinion provided under this clause.

6.8 Supplier Performance Management

Vendors will be continuously measured in line with the following components outlined previously in this chapter:

1. Vendor OTIF (chapter 6.3)
2. Vendor Lateness (chapter 6.3)
3. Vendor Pro-Active Communication (chapter 6.4 *NEW*)
4. Vendor Logistic Non-conformance (chapter 6.5)
5. Customer Complaints (chapter 6.7)

Vendors will be assessed along 2 axis:

1. Vendor priority and risk
2. Overall vendor performance, presented as a single KPI named **Vendor Performance Index (VPI)**

Vendors not conforming to the Supplier Performance Management policy may be requested to participate in corrective actions with SGSS in order to return performance to the desired level.

The minimum performance required as part of our Supplier Performance Management policy is as follows:

1. Vendor OTIF = 90%
2. Vendor Lateness = 10%
3. Vendor Pro-Active Communication = 95% response in 48 hours
4. VNC = <1 per 1000 lines
5. Quality = <1 per 1000 lines

Individual SLA may define a new minimum in specific cases.

6.9 Vendor Penalties

If necessary SGSS reserves the right to apply compensation charges to vendors at a weekly rate of outstanding poor performance without resolution as outlined throughout chapter 6, at 1% of the PO value per week limited to 10% of the overall PO value plus a €100 administration charge.

- On time delivery failure resulting in stock out of finished goods or raw materials
- Quality/ technical failure resulting in customer order failure or production failure

In addition SGSS will pass on penalty charges to vendors where SGSS have themselves been penalised as a direct consequence of the vendor's poor performance outlined above in section 6.6.

The vendor will also be charged for any costs the situation has generated including rework, industrial disruption, additional transport fees, resourcing, etc.

MORE DETAIL IS AVAILABLE WITHIN THE GENERAL CONDITIONS OF PURCHASE.

6.10 Appendices

Appendix 6.9-A - Vendor Non Conformance form - Front

Warning

Vendor Delivery Non Conformance **SupplyChain Fill Form**

Form N°3000-1-14-0481

Supplier response due by 07/06/2014

Creator	Wellard Mick	Creation Date(DD/MM/YYYY)	02/06/2014
Plants	9305		
Vendor Code	01002275</TD<>		
Vendor Name	X.B. & Sons LTD</TD<>		
Carrier	TLP</TD<>		
Purchase Order Number	4501856144		
Outbound Delivery	na		
Delivery Date (DD/MM/YYYY)	02/06/2014		

Inspection Details

Level of Non Conformance	Warning
--------------------------	---------

Goods in Findings

Non Conformance Reason	D4 - Incorrect pallet type
------------------------	----------------------------

Quality Control Action Report: Evidence

Auditor Comment - Photograph 1	
Auditor Comment - Photograph 2	
Auditor Comment - Photograph 3	

SupplyChain - Fill Form

Identification Supply Chain - Fill Form

Responsible Supply Chain - Fill Form	Forse Robert	Date Supply Chain - Fill Form (DD/MM/YYYY)	02/06/2014
--------------------------------------	--------------	--	------------

6.10 Appendices

Appendix 6.9-A – Vendor Non Conformance form - Back

Delivery Details	
Email Contact	joe@xb&sons.com
Proposed Remedial Action	
Remedial Action	Goods not on EPAL pallets. Please make all palletised deliveries using EPAL grade pallets
Recharge?	NO
Proposed Value	0
Ref	4501856144
Saint-Gobain Recharge Comment	
Supply Chain - Fill Supplier	
You must complete fields outlined in red	
Identification Supply Chain - Fill Supplier	
SGA Supply Chain Coordinator	Forse, Robert
*Date Supply Chain - Fill Supplier (DD/MM/YYYY)	
Informations - Recharge	
*Recharge Agreed	NO
Actual Recharge value	0
Vendor Recharge Comments	
Supplier Response	
Actual Response Date	
What action has been taken with stock at SGA	
What action has been taken by supplier to resolve the current situation and prevent recurrence	1

1 For vendor completion and return to SGSS Staff or Supply Chain or Purchasing contact

6.10 Appendices

Appendix 6.9-B – An example 8D report - Front

	Corrective & Preventive Action Feedback <i>Saint-Gobain Eibergen –Holland</i>		SGA 8D report	
			Version: A/0	
			Date:	
			Page: 1	
<input checked="" type="checkbox"/> Priority <input type="checkbox"/> General	Supplier <input type="checkbox"/> Internal <input checked="" type="checkbox"/> External		File ID:	
Infected batch number:	SGA rep. : DR.			
Supplier:	1.Owner of problem at supplier:			
2.Description of problem:				
3.Temporary Action / trouble-shooting:			Date:	Verified:
4.Root Cause (RC):			Influence Rate (%):	
5.Corrective Action Taken:			Deadline:	Verified by:
Describe also action taken on infected stock:				
6.Preventive Action:			Deadline:	Verified by:
7. When is solution installed?				
8. Any impact on control plan / work instruction e.g.:				
<input type="checkbox"/> Accept <input type="checkbox"/> Reject		Checked by: SGA name Date: 2013.xx.xx	Closed by: SGA name Date: 2013.xx.xx	

6.10 Appendices

Appendix 6.9-B – An example 8D report - Back



Explanation / how to use 8d procedure:

- D1 : Compose a team. To mobilize all the knowledge and skills , it is important to establish a multidisciplinary team
- D2 : Describe the problem. The problem must be, from the viewpoint of the problem holder , be described objective and clear as possible,
- D3 : Solve problem temporarily . Sometimes it is necessary to solve it very quickly. Finding the best solution is to worry about later .
- D4 : Find the cause(s). Before making a final solution to be carried through it is necessary to determine the cause of the problem in the form.
For this reason find different methods can be used . (Is- Is not , Ishikawa or fishbone diagram , and who, what , when, why and how) .
- D5 : Find the solution. If the cause of the problem is known, it can be directed to find the best solution. Here too, different dis- solution methods can be used . (Morphological overview, Value Analysis , Engineering Principles and Creativity Techniques)
- D6 : Implement solution. Once the final solution is known, then, in this phase follows the realization.
- D7 : Prevent problem. Usually there are additional measures necessary to prevent similar problems in the future
- D8 : Reward the team: The last and perhaps the most important step in the 8D methodology is rewarding the team

SPECIFICS

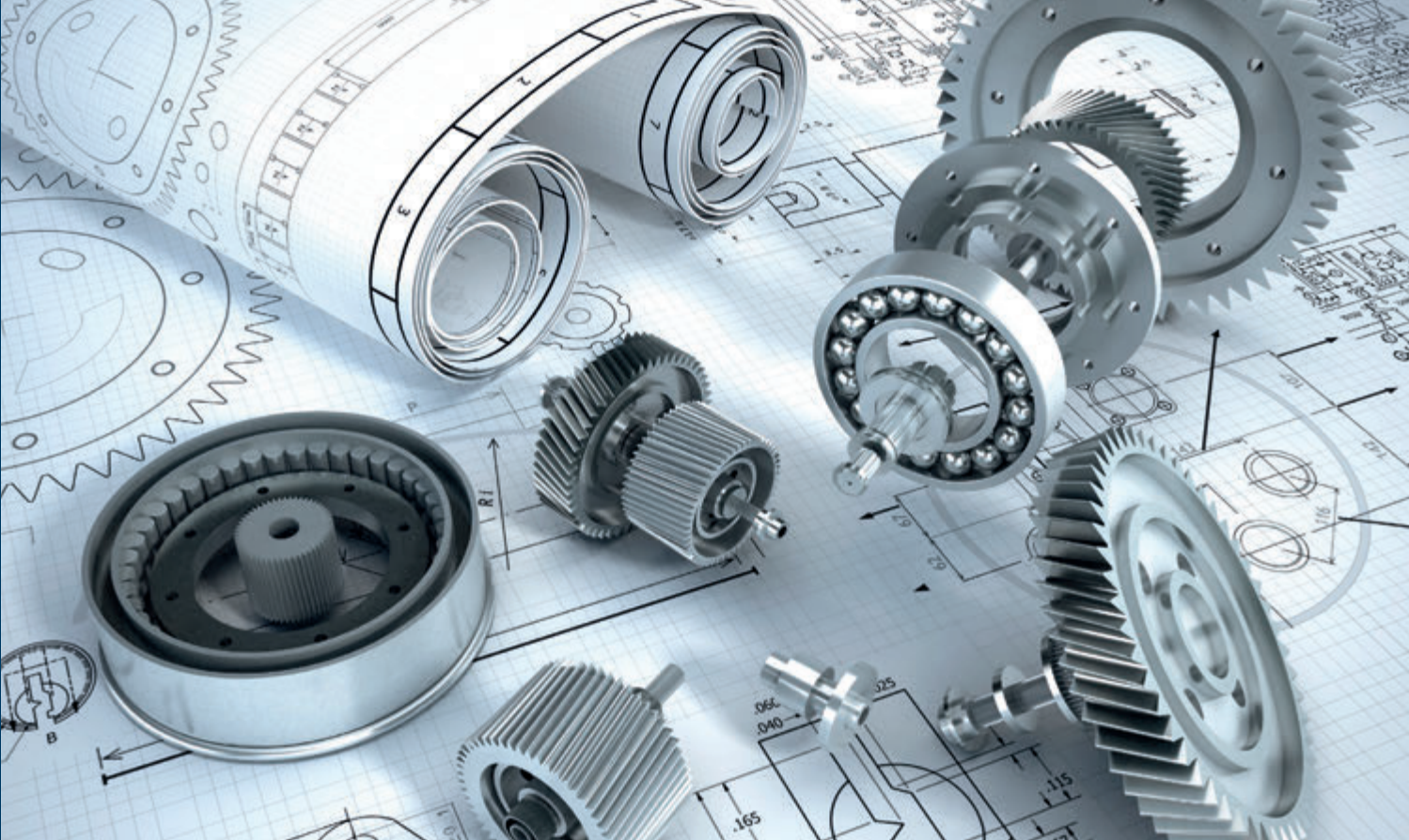

7.1 Tools

The tools dedicated and paid for by SGSS are its property and are identified “Property of Saint-Gobain Surface Solutions” in a robust and durable way as such by the vendor. The vendor provides upon request the pictures of the identified tools. The vendor will not sell or supply parts produced with these tools to third parties without SGSS agreement.

The vendor is solely responsible for the maintenance and safeguard of the tools until the end of the production (including spare parts).

At the end of the production, the vendor cannot destroy or dispose of the tools without SGSS written authorisation (in case of refusal, the vendor can return the tool to SGSS). Any destruction without prior written SGSS authorisation will lead to realisation of new tools at the vendor’s expense or full compensation.

All the characteristics indicated on the drawing are SGSS property and cannot be disclosed without prior SGSS written authorisation.

7.2 Specifications, Drawings and Copyright

The vendor assigns (free of all third party rights) all copyright, design rights or other intellectual property or proprietary rights created or developed as a result of or in any connection with this relationship to SGSS.

Any tools, patterns, dies, moulds, jigs, fixtures, drawings, designs or any other forms of intellectual property rights in all drawings, specifications, data and artwork furnished to the vendor by SGSS, or fully or partially paid for by SGSS shall be the property of SGSS and subject to removal by SGSS upon termination of this relationship, and shall be used only in fulfilling the relationship. The vendor will maintain this intellectual property in good condition, in safe custody at its own risk until returned to SGSS and will not be disposed of other than in accordance with SGSS written instructions.

The vendor agrees not to make any use of goods, tooling, data, designs, or any other forms of intellectual property rights in all drawings, specifications, artwork and other information furnished by SGSS or created hereunder, except for the performance of the contract and in accordance with SGSS instructions.

The vendor agrees not to disclose such data, designs, drawings, specifications, artwork or other information to any third party other than as necessary for the purposes of enabling it to perform its obligations under the contract.

Upon completion or termination of the relationship, the vendor shall return to SGSS on demand all such tooling, data, designs, drawings, specifications and other material or information, including artwork and any copies thereof made by the vendor.

This contract is confidential between SGSS and the vendor, and it is agreed by the vendor that none of the details connected herewith or the relationship between the parties shall be published or disclosed to any third party without SGSS written permission.

The vendor will ensure that all goods supplied to SGSS are free from asbestos and/or asbestos contamination.



ANNEXE

Environment, Health and Safety

EHS Charter

*Let's commit ourselves, every day,
to achieving our objectives:*

- ZERO** work related accidents,
- ZERO** occupational illnesses,
- ZERO** environmental accidents
and **minimum impact** of our activities.

By adhering to the following principles:

- **RESPECT** for relevant legislation as well as for Saint-Gobain standards,
- **EXEMPLARY** standards in all our processes, products and services, throughout their life cycle,
- **PREVENTION** and continuous reduction of all risks for our employees, temporary workers, sub-contractors, visitors and customers, as well as for the environment,
- **DIALOGUE** continuous, responsible and open with our stakeholders (colleagues, public authorities, neighbours, customers, suppliers, etc).



Environment, Health and Safety

EHS Policy

Dear colleagues,

Saint-Gobain designs, manufactures and distributes materials, services and solutions which are key contributors to our sustainable wellbeing. Through our commitment to environmental, health and safety excellence, we affirm to all our stakeholders, including our employees, customers, suppliers, shareholders and the public that we aim at working collaboratively to bring sustainable, market-driven and innovative solutions, making lives better, safer and healthier for people everywhere. It is part of our General Principles of Conduct and Action and a common value.

We believe that any injury, occupational illness or environmental accident is unacceptable. Excellence in environment, health and safety is contributing directly to the improvement of working conditions, to the operational excellence and to the wellbeing of all. As indicated on the EHS Charter displayed in all our sites, each and every one of us must be committed to work tirelessly with engagement and determination to achieve our ultimate goal: zero work related accident, zero occupational illness, zero environmental accident and minimum impact of our activities to the environment.

We establish and maintain our standards and best practices in light of advances in technology and science and aim at a wide implementation. We strengthen our businesses by making safety, health and environment central to our culture.

We assess the impact of any site we propose to construct or acquire and we design and build all our sites, so that they are safe, secure and acceptable to the environment.

We continuously analyze our practices, processes and products to minimize their environmental, health and safety risks and impacts and to maximize their benefits.

We measure and regularly report our global progress in meeting this Engagement.

The management of each business is responsible for educating, training and motivating employees to understand and comply with this Engagement. Within the general frame established by Compagnie de Saint-Gobain, each Sector defines a specific EHS action plan relating to its particular activities and processes. Each Delegation coordinates EHS actions across business units, particularly those related to the specific conditions of a country. The entire local management is committed to ensuring the full implementation and application of the EHS policy and to lead by example with its behavior.

The Group executive directors and I are timely informed about key environmental, health and safety issues with regular report to the Board of Directors. I will ensure, together with the management, that policies and resources are in place and actions are taken to achieve this Engagement. Compliance with this Engagement is the responsibility of every employee and contractor acting on our behalf and is a condition of their employment or contract.

I know that I can count on your personal commitment and involvement.



Pierre-André de Chalendar
Président-Directeur Général





TIMBER POLICY

SAINT-GOBAIN GROUP

MEMO, V1.0

09/2013



Saint-Gobain's timber policy defines the responsible conduct with which Saint-Gobain subsidiaries are required to comply when buying and/or selling timber products. It specifies a set of common operating rules.

This policy is part of the **response of the Saint-Gobain Group to the major challenges of sustainable development.**

It reflects our determination to set an exemplary standard for all our products throughout their life-cycle. Moreover it contributes to our objective of maximum possible reduction of the impact of our activities.

We have defined three areas of action directly inspired by the Group's Principles of Conduct & Action.

RESPECT FOR OTHERS

Ensuring respect for fundamental rights of local populations

We are committed to:

- ensuring that we buy and sell timber harvested in countries or concessions that comply with international conventions.
-

CARING FOR THE ENVIRONMENT

Using timber harvested in responsibly managed concessions in order to preserve natural resources

We are committed to:

- giving priority to recycled products first in our purchasing and sales policies, then either PEFC/FSC certified products or timber from responsibly managed forests.

Contributing to biodiversity preservation

We are committed to:

- adapting our sales and purchasing policy depending on the level of species vulnerability.
-

RESPECT FOR THE LAW

Ensuring the legality of the timber we import, use and sell

In particular in compliance with the European Timber Regulation (EUTR) under the FLEGT action plan in Europe and with the Lacey Act in the US.

We are committed to:

- gradually developing a traceability system for all the timber products we buy and sell,
- implementing a system to evaluate and control risks linked to the timber trade.

SAINT-GOBAIN ABRASIVES NV/SA

Industrielaan 129
1070 Anderlecht
Brussels
BELGIUM
TEL: +32 2 267 21 00
FAX: +32 2 267 84 24

SAINT-GOBAIN ABRASIVES, S.R.O.

Počernická 272/96, Malešice
108 00 Praha 10
CZECH REPUBLIC
TEL: +420 255 719 326
FAX: +420 255 719 321

SAINT-GOBAIN ABRASIVES A/S

Robert Jacobsens Vej 62A
2300 København S
DENMARK
TEL: +45 4675 5244

PO BOX 643706

Fortune Tower office 2106
JLT Block C
(next to metro station)
Jumeira Lake Tower, DUBAI
United Arab Emirates
TEL: +971 4 431 5154
FAX: +971 4 431 5434

SAINT-GOBAIN ABRASIFS

RUE DE L'AMBASSADEUR - B.P.8
78 702 CONFLANS CEDEX
FRANCE
TEL: +33 (0)1 34 90 40 00
FAX: +33 (0)1 39 19 89 56

SAINT-GOBAIN ABRASIVES GMBH

BIRKENSTRASSE 45-49
D-50389 WESSELING
GERMANY
TEL: +49 (0) 2236 703-1
+49 (0) 2236 8996-0
+49 (0) 2236 8911-0
FAX: +49 (0) 2236 703-367
+49 (0) 2236 8996-10
+49 (0) 2236 8911-30
Für den Fachhandel Österreich
TEL: +43 (00) 662 430 076

SAINT-GOBAIN ABRASIVES KFT.

1225 Budapest
Bányalég u. 60/B.
Hungary
TEL: +36 1 371 22 50
FAX: +36 1 371 22 55

SAINT-GOBAIN ABRASIVI S.P.A

VIA PER CESANO BOSCONI 4
I-20094 CORSICO MILANO
ITALY
TEL: +39 02 44 851
FAX: +39 02 44 78 266

SAINT-GOBAIN ABRASIVES S.A.

190 RUE J.F. KENNEDY
L-4930 BASCHARAGE
GRAND DUCHE DE LUXEMBOURG
TEL: +352 50 401 1
FAX: +352 50 16 33
NO. VERT (France) 0800 906 903

SAINT-GOBAIN ABRASIFS, S.A.

2 ALLÉE DES FIGUIERS
AIN SEBAÅ - CASABLANCA
MOROCCO
TEL: +212 5 22 66 57 31
FAX: +212 5 22 35 09 65

SAINT-GOBAIN ABRASIVES BV

GROENLOSEWEG 28
7151 HW EIBERGEN
P.O. BOX 10
7150 AA EIBERGEN
THE NETHERLANDS
TEL: +31 545 466466
FAX: +31 545 474605

SAINT-GOBAIN ABRASIVES AS

Postboks 11, Alnabru, 0614 Oslo
Brobekkveien 84
0582 Oslo
Norway
TEL: +47 63 87 06 00
FAX: +47 63 87 06 01

SAINT-GOBAIN HPM POLSKA SP. Z O.O.

ul. Norton 1
62-600 Koło
Poland
TEL: +48 63 26 17 100
FAX: +48 63 27 20 401

SAINT-GOBAIN ABRASIVOS, LDA.

RUA DE RODRIGO SILVA, 122
4475-187 MAIA
PORTUGAL
TEL: +351 229 437 940
FAX: +351 229 437 949

**SAINT-GOBAIN GLASS,
BUSINESS UNIT ABRASIVI
PUNCT DE LUCRU:**

loc.Vetis, jud. Satu Mare
447355, str. Careiului 11,
Parc Industrial Renovatio
ROMANIA
TEL: +40 261 839 709
FAX: +40 261 839 710

SG HPM RUS

58, F. Engels Str.
Stroenie 2
105082 Moscow
Russia
TEL: +74 955 408 355
FAX: +74 959 373 224

SAINT-GOBAIN ABRASIVES (PTY) LTD

2 MONTEER ROAD
ISANDO 1600
P.O. BOX 67
SOUTH AFRICA
TEL: +27 11 961 2000
FAX: +27 11 961 2184/5

SAINT-GOBAIN ABRASIVOS, S.A.

CTRA. DE GUIPÚZCOA, KM. 7,5
E-31195 BERRIOPLANO (NAVARRA)
SPAIN
TEL: +34 948 306 000
FAX: +34 948 306 042

SAINT-GOBAIN ABRASIVES AB

Box 495
SE-191 24 Sollentuna
SWEDEN
TEL: +46 8 580 881 00
FAX: +46 8 580 881 01

SAINT-GOBAIN INOVATIF MALZEMELER VE

Aşındırıcı San. Tic. A.Ş.
Gold Plaza, Altay Çeşme Mahallesi,
Öz Sokak, No:19/16
34843 Maltepe-Istanbul ,
Turkey
Tel: 0090-216-217 12 50
Fax: 0090-216-442 40 74

SAINT-GOBAIN ABRASIVES

UNICORN HOUSE
UNIT 1, AMISON CLOSE
REDHILL BUSINESS PARK
STAFFORD
ST16 1WB
UNITED KINGDOM
TEL: +44 1785 279553
FAX: +44 1785 213487

**Saint-Gobain Abrasifs**

European Headquarters
Rue de l'Ambassadeur - B.P.8
78 702 Conflans Cedex
France
Tel: +33 (0)1 34 90 40 00
Fax: +33 (0)1 39 19 89 56